

CARBON STEEL TAP MANUFACTURING PROCESS

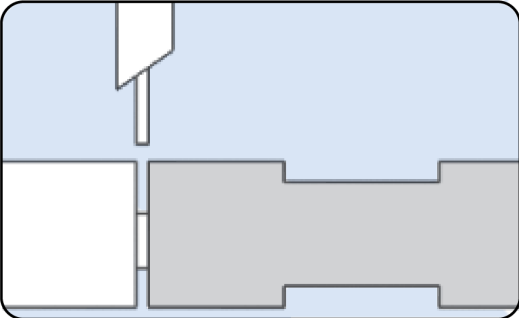

1. Automatic cutting and forming of blank.

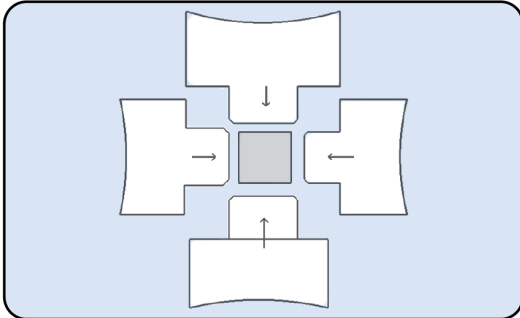

2. Press squaring shank end.

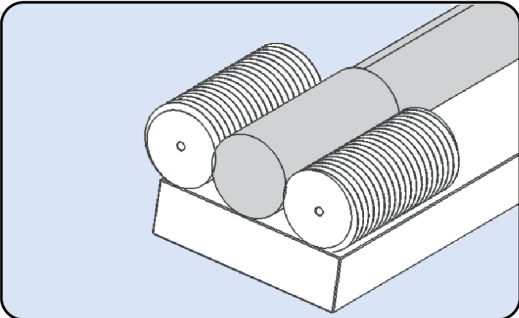

3. Roll threads per inch

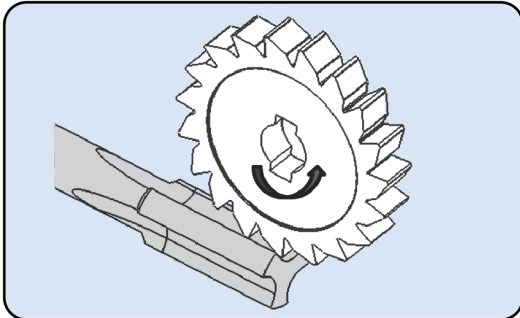

4. Flute milling.

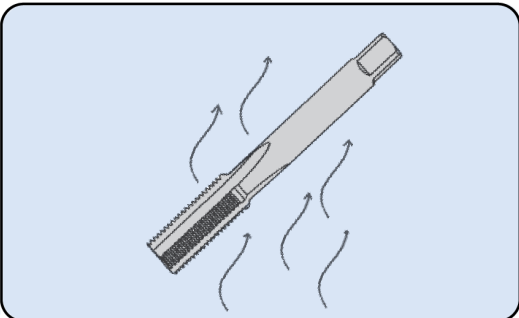

5. Harden and temper.

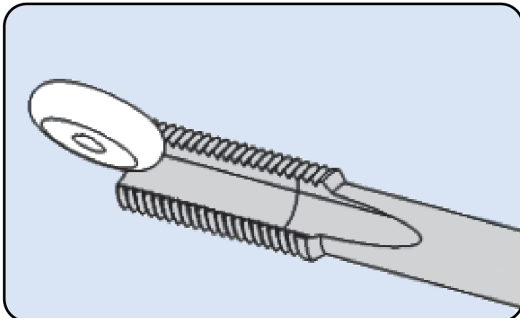

6. Flute grind rake angle.

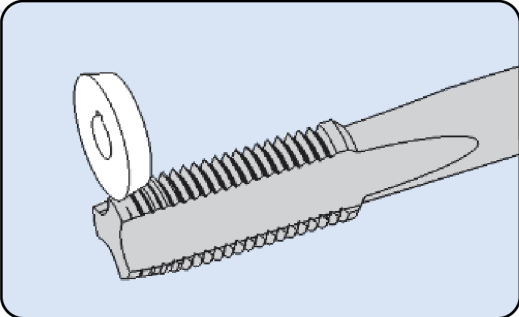

7. Chamfer grinding angle. Bottom, Plug, or Taper.

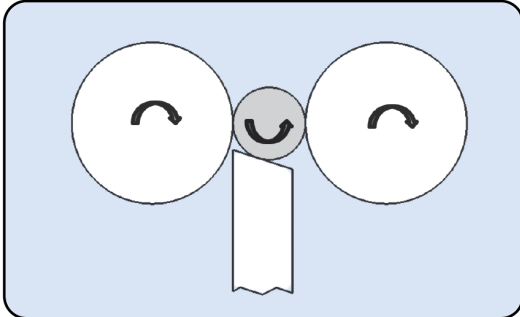

8. Centerless grinding shank diameter.

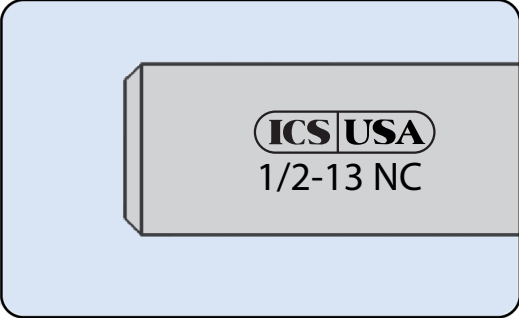

9. Laser marking logo and size.

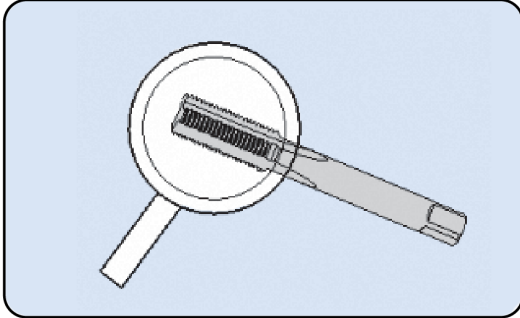

10. Final inspection.