

TECHNICAL

American National Standard Tapers

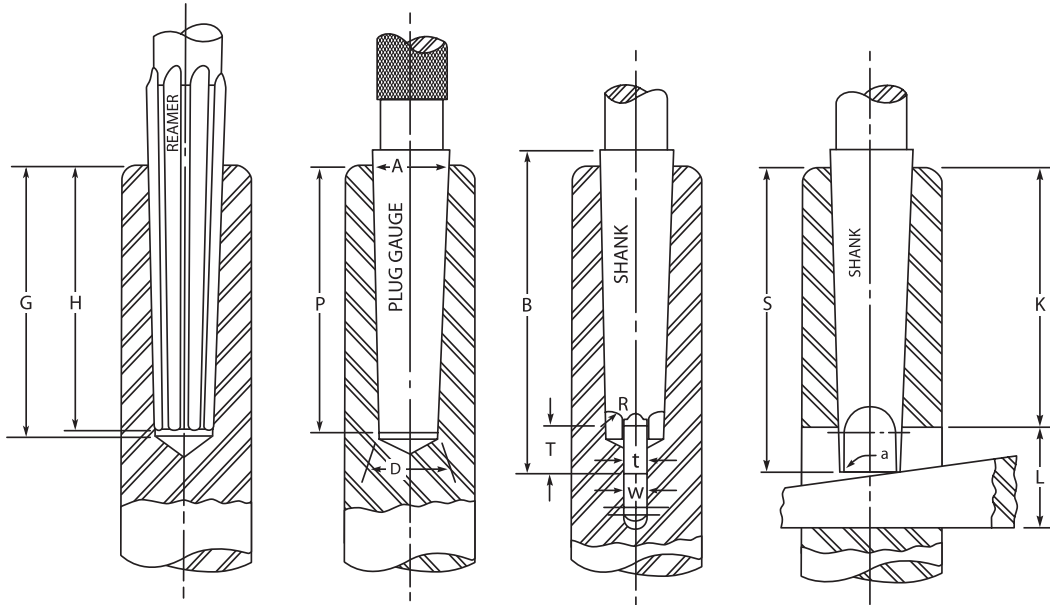

Detail Dimensions*

Morse Taper Number	Shank							Tang				Tang Slot			Taper per Inch	Taper per Foot
	Diameter of Plug at Small End	Diameter at End of Socket	Whole Length	Depth	Depth of Drilled Hole	Depth of Reamed Hole	Standard Plug Depth	Thickness	Length	Radius	Radius	Width	Length	End of Socket to Tang Slot		
	D	A	B	S	G	H	P	t	T	R	a	W	L	K		
0	.25200	.35610	2-11/32	2-7/32	2-1/16	2-1/32	2	5/32	1/4	5/32	3/64	11/64	9/16	1-15/16	.052050	.62460
1	.36900	.47500	2-9/16	2-7/16	2-3/16	5-5/32	2-1/8	13/64	3/8	3/16	3/64	7/32	3/4	2-1/16	.049882	.59858
2	.57200	.70000	3-1/8	2-15/16	2-21/32	2-39/64	2-9/16	1/4	7/16	1/4	1/16	17/64	7/8	2-1/2	.049951	.59941
3	.77800	.93800	3-7/8	3-11/16	3-5/16	3-1/4	3-3/16	5/16	9/16	9/32	5/64	21/64	1-3/16	3-1/16	.050196	.60235
4	1.02000	1.23100	4-7/8	4-5/8	4-3/16	4-1/8	4-1/16	15/32	5/8	5/16	3/32	31/64	1-1/4	3-7/8	.051938	.62326
4-1/2	1.26600	1.50000	5-3/8	5-1/8	4-5/8	4-9/16	4-1/2	9/16	11/16	3/8	1/8	37/64	1-3/8	4-5/16	.052000	.62400
5	1.47500	1.74800	6-1/8	5-7/8	5-5/16	5-1/4	5-3/16	5/8	3/4	3/8	1/8	21/32	1-1/2	4-15/16	.052626	.63151
6	2.11600	2.49400	8-9/16	8-1/4	7-13/32	7-21/64	7-1/4	3/4	1-1/8	1/2	5/32	25/32	1-3/4	7	.052138	.62565
7	2.75000	3.27000	11-5/8	11-1/4	10-5/32	10-5/64	10	1-1/8	1-3/8	3/4	3/16	1-5/32	2-5/8	9-1/2	.052000	.62400

* Table agrees with American National Standards for Taper Shanks except for angle and undercut of tang.



511 Main Street • P.O. Box 125
 Casco, WI 54205-0125 USA
www.icscuttingtools.com

920-837-2526
 FAX 920-837-2530
info@icscuttingtools.com