



HIGH SPEED STEEL FAST/SLOW SPIRAL JOBBER LENGTH DRILLS

ICS USA

SPECIAL PURPOSE

118° POINT

ITEM NO.	ILLUSTRATION	CUTTING APPLICATION	STEEL SPECS	TECHNICAL DATA
JDF	 BRIGHT POLISHED FINISH	For portable or machine drilling low tensile strength materials such as aluminum, magnesium, copper, zinc, and similar materials producing long stringy swarf. Excellent chip-clearing when drilling deep holes.	M2	118° Point Fast Spiral Std. Web
JDS	 BRIGHT POLISHED FINISH	For portable or machine drilling in brass, copper, and similar alloys. Also for soft copper and aluminum sheet where breakout "snatch" or burr is a problem. Polished ground flutes ease chip ejection.	M2	118° Point Slow Spiral Std. Web

Fractional Sizes (Straight Shank) 1/16" to 1/2" Dia.

SIZE	DEC. EQUIV.	FLUTE LENGTH	OVERALL LENGTH	HIGH SPEED STEEL	
				BRIGHT FINISH 118° POINT	
				JDF	JDS
1/16	.0625	7/8	1-7/8	2.12	2.46
5/64	.0781	1	2	2.16	2.46
3/32	.0938	1-1/4	2-1/4	2.16	2.42
7/64	.1094	1-1/2	2-5/8	2.12	2.46
1/8	.1250	1-5/8	2-3/4	2.12	2.42
9/64	.1406	1-3/4	2-7/8	2.12	2.46
5/32	.1562	2	3-1/8	2.32	2.96
11/64	.1719	2-1/8	3-1/4	2.80	3.44
3/16	.1875	2-5/16	3-1/2	3.10	3.42
13/64	.2031	2-7/16	3-5/8	3.56	4.10
7/32	.2188	2-1/2	3-3/4	3.86	4.64
15/64	.2344	2-5/8	3-7/8	4.40	5.24
1/4	.2500	2-3/4	4	4.18	4.90
17/64	.2656	2-7/8	4-1/8	5.66	6.34
9/32	.2812	2-15/16	4-1/4	5.64	6.60

SIZE	DEC. EQUIV.	FLUTE LENGTH	OVERALL LENGTH	HIGH SPEED STEEL	
				BRIGHT FINISH 118° POINT	
				JDF	JDS
19/64	.2969	3-1/16	4-3/8	6.52	7.82
5/16	.3125	3-3/16	4-1/2	6.70	8.12
21/64	.3281	3-5/16	4-5/8	7.78	8.86
11/32	.3438	3-7/16	4-3/4	8.26	9.82
23/64	.3594	3-1/2	4-7/8	10.26	13.24
3/8	.3750	3-5/8	5	9.94	11.70
25/64	.3906	3-3/4	5-1/8	11.92	14.66
13/32	.4062	3-7/8	5-1/4	11.62	13.48
27/64	.4219	3-15/16	5-3/8	13.86	17.20
7/16	.4375	4-1/16	5-1/2	13.64	15.62
29/64	.4531	4-3/16	5-5/8	14.94	20.12
15/32	.4688	4-5/16	5-3/4	15.36	19.18
31/64	.4844	4-3/8	5-7/8	16.82	22.64
1/2	.5000	4-1/2	6	16.26	20.02

HIGH SPEED STEEL FAST/SLOW SPIRAL JOBBER LENGTH DRILL SETS

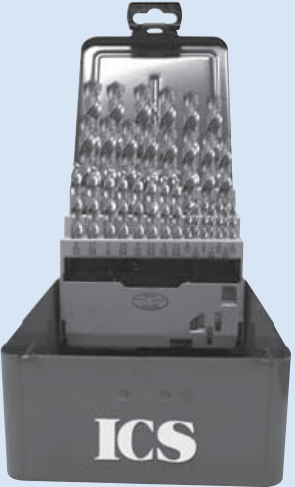
DESCRIPTION	TYPE OF DRILL	ITEM NO.	PRICE
 29 PC DRILL SETS Sizes 1/16 to 1/2 by 64ths METAL INDEX	Fast Spiral Jobber Drill - 118° Pt	DS-JDF-29	182.20
	Slow Spiral Jobber Drill - 118° Pt	DS-JDS-29	210.66