

# T-HANDLE TAP WRENCHES

ICS USA

GENERAL PURPOSE

FIXED JAWS

## Plain Type

T-Handle Tap Wrenches are designed for hand tapping. They also can be used with reamers, drills, and screw extractors. T-Handle may be slipped from side to side for complete turns in close quarters or be extended full length in either direction for more leverage.

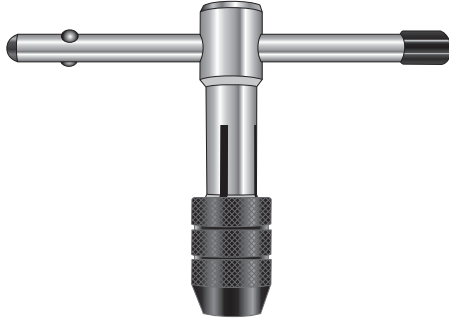

TAP CAPACITY	ITEM NO.	PRICE
#0 - 1/4	TTW-1	5.22
#12 - 5/16	TTW-2	-
1/4 - 1/2	TTW-3	9.14

## 3/8" Square Drive Type

T-Handle Tap Wrenches with 3/8" square drive are designed with a removable handle to insert a 3/8" ratchet or extension when desired. All other features are same as regular T-Handle Tap Wrenches.

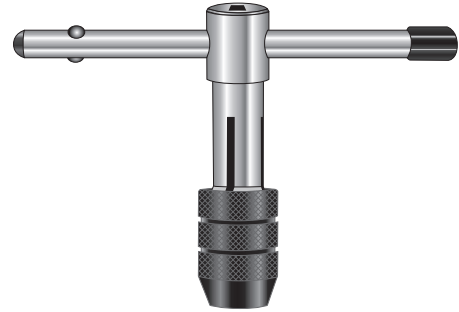

TAP CAPACITY	ITEM NO.	PRICE
1/4 - 1/2	TTWSD3	13.58

# T-HANDLE TAP WRENCHES

ICS USA

HEAVY DUTY

FIXED JAWS

## Piloted Spindle

T-Handle Tap Wrenches with a piloted spindle are designed for threading a drilled hole manually on a drill press or lathe, without moving the work piece from set-up.

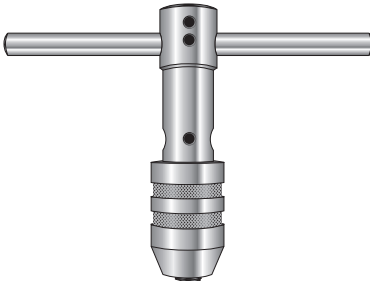

TAP CAPACITY	ITEM NO.	PRICE
#0 - 1/4	TTWP-1	16.24
1/4 - 1/2	TTWP-2	23.72
1/2 - 3/4	TTWP-3	54.66

## Ratchet Type

T-Handle Tap Wrenches with a ratchet and slip handle are designed with a selector switch for left, right, or rigid operation.

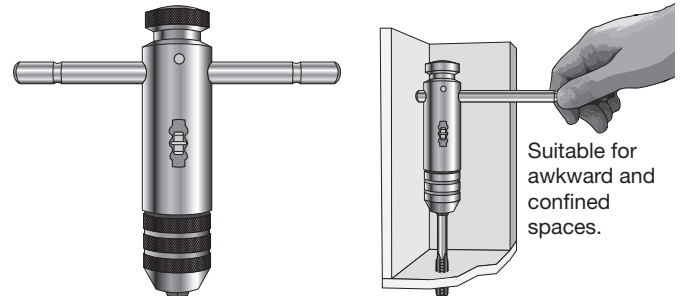

Suitable for awkward and confined spaces.

TAP CAPACITY	ITEM NO.	PRICE
#0 - #8	TTWR-1	18.32
#8 - 1/4	TTWR-2	19.98
1/4 - 1/2	TTWR-3	24.28